

## VIP-801A NETWORK AUDIO PORT

### INTRODUCTION

The VIP-801A Network Audio Port enables voice access to a single zone of one-way paging over an IP network, allowing page zones to be extended anywhere network connectivity is available. The VIP-801A can be programmed as a SIP (Session Initiation Protocol) device for connectivity to virtually any Voice over IP (VoIP) telephone system.



### SPECIFICATIONS

#### Features

- 1 Audio Input
- 2 Audio Outputs
- 2 Form C Relays
- 1 Contact Closure Input
- 1 SIP identity for registering to a VoIP telephone system
- RJ-45 jack for network connection
- Front panel activity LED
- Provides audio for up to 40 Valcom one-way amplified speaker assemblies
- AUX audio input via RCA jack
- Contact closure or VOX operation of audio input
- Removable screw terminal connectors provided for audio and relay interfaces
- AUX input music mutes during page
- Output control contact closure provided during paging output
- Compatible with 25 or 70 Volt amplifiers
- Barrel jack for optional DC power
- Power over Ethernet (PoE) 802.3af compatible

#### Dimensions/Weight

- 1.38 H x 6.13" W x 5.25" D  
(3.50cm H x 15.6cm W x 13.33cm D)
- Weight: 1.25 lbs. (0.57 kg)

#### Nominal Specifications

Input Impedance:	600 Ohms
Input Level:	-10dBm nominal
Voice Switch Sensitivity:	-21dBm
AUX Input Impedance:	8 to 600 Ohms
AUX Input Level:	-10dBm nominal
Output Impedance:	50 Ohms
Output Level:	- 10dBm nominal
Relay Current:	1 Amp @ 24VDC

#### Nominal Power Requirements

##### Via rear panel barrel connector:

Voltage:	24VDC
Current:	325mA

##### Via 802.3af PoE Ethernet Switch:

802.3af:	Class 3
----------	---------

#### Environment

Temperature:	0 to +40° C
Humidity:	0 to 85% non-precipitating

#### Packing List

Qty	Item
1	VIP-801A
1	VSP Document
2	Mounting Brackets W/ Hardware
4	Rubber Pads

## INSTALLATION

### FCC Information

This equipment has been tested and found to comply with the limits for a Class A digital device, pursuant to Part 15 of the FCC Rules. These limits are designed to provide reasonable protection against harmful interference when the equipment is operated in a commercial environment. This equipment generates, uses and can radiate radio frequency energy and if not installed and used in accordance with the instruction manual, may cause harmful interference to radio communications.

Operation of this equipment in a residential area may cause harmful interference in which case the user will be required to correct the interference at his own expense.

### Precautionary Designations

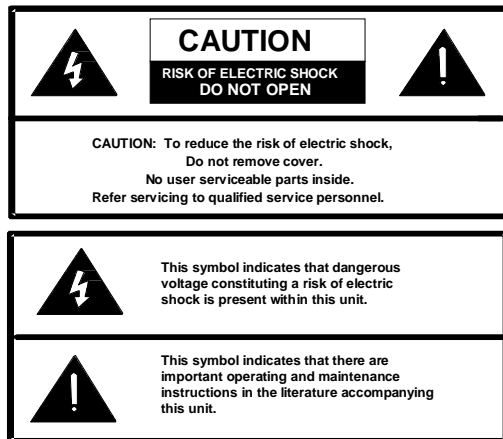

### Mounting

The VIP-801A is designed for wall or table mounting.

**Table:** Provided with the VIP-801A are four rubber pads. Peel the pads from their carrier backing and place at the four corners of the bottom of the unit.

**Wall:** Using the brackets and screws provided, secure the VIP-801A to the wall.

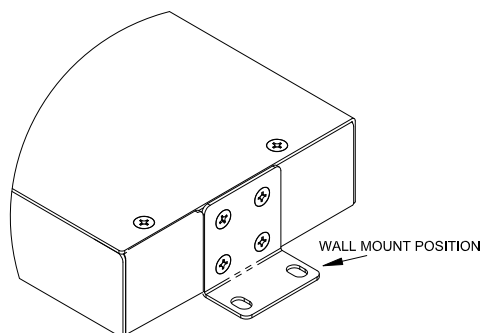

### Power Connections

The preferred method of powering a VIP-801A is via a Power over Ethernet (PoE) switch meeting the 802.3af specification.

If the rear panel barrel connector is used for power, the preferred power supply is a Valcom VIP-324D.

Make all required signal connections before applying power to the unit. If powering via 802.3af, make sure all signal connections via the back panel are made then connect the VIP-801A to the Ethernet switch.

If power is supplied via the barrel connector, make sure all signal connections are secure. Attach the unit to the network via the front panel RJ-45 Ethernet connector. Apply power by plugging the power supply into the VIP-801A via the barrel connector on the rear of the VIP-801A.

### Network Connection

The VIP-801A has one RJ-45 network connector on the front panel. Use a standard Ethernet patch cable to connect the VIP-801A to an Ethernet switch.

### Signal Connections

The VIP-801A has signal connectors on the rear panel:

- RCA jack for AUX audio input
- 2 Audio outputs
- 2 Form relays
- 1 Audio input
- 1 Contact Closure input

**AUX Input:** Local audio may be input via the rear panel RCA jack. Nominal input impedance is 600 Ohms. Connect any compatible audio source using an RCA patch cable. Audio supplied through the rear panel RCA jack is transformer coupled to both Audio Out terminals when paging is idle. This is typically used for background music.

**Audio Out:** Two audio output connections are provided. The terminals labeled "Page" provide a signal output compatible with Valcom self-amplified speakers. Up to 40 Valcom speakers can be connected to the Page output. The terminals labeled "AUX" provide a signal output compatible with most amplifiers and should be used where a transformer-coupled output is desired.

**DIP Switch:** The four-pole DIP switch controls a supervision signal on the "Page" audio output line. For systems where supervision is used, setting DIP switches 1 & 2 to ON enables supervision on the Page audio output connections. Where supervision is not used, set DIP switches 1 & 2 to OFF. Switches 3 & 4 are not used.

**Audio Input/Contact Closure:** One Audio Input and one Contact Closure input are provided. Neither input is polarity sensitive. The contact closure is labeled "CC". The audio input terminals are labeled "AUDIO".

**Relay Channels:** Access to the two form C relays is provided via a six pin screw terminal block. The relays are labeled K1 and K2. Each relay is brought out on three terminals. The common contact is the middle terminal with the normally closed contact on the right and the normally open contact on the left. Relay contacts are rated for 1A @ 24VDC.

## Status Indicator Lights

The VIP-801A has 3 status indication lights on the front panel:

**STATUS:** Flashes during normal operation and solid during system startup.

**Green LED:** (Link) Indicates Ethernet connection when illuminated.

**Yellow LED:** (Activity) Indicator flashes to indicate network activity.

## Setup

Information specific to your application will need to be programmed into the VIP-801A using a computer. The PC used for programming should be connected to the same subnet as the VIP-801A. Setup will be done using the IP Solutions Setup Tool. Download the latest version of the free IP Solutions Setup Tool from the Valcom web site at [www.valcom.com/vipsetuptool](http://www.valcom.com/vipsetuptool).

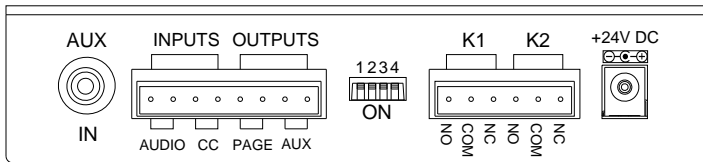

**Rear View**

## TECHNICAL ASSISTANCE

When trouble is reported, verify power is being supplied to the unit and there are no broken connections. If a spare unit is available, substitute a spare unit for the suspected defective unit.

Assistance in troubleshooting is available from the factory. Call (540) 563-2000 and press 1 for Technical Support or via email at support@valcom.com.

When requesting assistance, you should include all available information. General information and

troubleshooting procedures are available on the Valcom website at [www.valcom.com](http://www.valcom.com).

Valcom equipment is not field repairable. Valcom, Inc. maintains service facilities in Roanoke, VA. Should repairs be necessary, attach a tag to the unit clearly stating your company name, address, phone number, contact person and the nature of the problem. Send the unit to:

**Valcom, Inc.  
Repair & Return Dept.  
5614 Hollins Road  
Roanoke, Va. 24019-5056**

### VALCOM LIMITED WARRANTY

Valcom, Inc. warrants its products only to the original purchaser, for its own use, to be free from defects in materials and workmanship under conditions of normal use and service for a period of one year from the date of shipment. This Limited Warranty obligation shall be limited to the replacement, repair or refund of any such defective device within the warranty period, provided that:

1. inspection by Valcom, Inc. indicates the validity of the claim;
2. the defect is not the result of damage, misuse or negligence after the original shipment;
3. the product has not been altered in any way or repaired by others and that factory sealed units are unopened (a service charge plus parts and labor will be applied to units defaced or physically damaged);
4. freight charges for the return of products to Valcom are prepaid;
5. all units 'out of warranty' are subject to a service charge. The service charge will cover minor repairs (major repairs will be subject to additional charges for parts and labor).

**This Limited Warranty is in lieu of and excludes all other warranties, expressed or implied and in no event shall Valcom, Inc. be liable for any anticipated profits, consequential damages, loss of time or other losses incurred by the buyer in connection with the purchase, operation, maintenance, installation, removal or use of the product. The maximum liability of Valcom under this warranty is limited to the purchase price of the specific Product covered by the warranty.**

**Disclaimer.** Except for the Limited Warranty provided herein, the product is provided "as-is" without any warranty of any kind whatsoever including, without limitation, any **WARRANTY OF MERCHANTABILITY, FITNESS FOR A PARTICULAR PURPOSE OR NON-INFRINGEMENT.**

This warranty specifically excludes damage incurred in shipment. In the event a product is received in damaged condition, the carrier should be notified immediately. Claims for such damage should be filed with the carrier involved in accordance with the F.O.B. point.

Headquarters:

Valcom, Inc.

5614 Hollins Road Roanoke, VA 24019-5056

Phone: (540) 563-2000 FAX: (540) 362-9800